



Junior MULTI-PURPOSE FRYER

Model WOG-20MP

- Revolutionize the way you cook with the **Junior Multi-Purpose Fryer**. Utilizing a short frying cycle and low frying temperatures, the model WOG-20MP is designed to save you money on both energy and shortening.
- The **Junior Multi-Purpose Fryer** fulfills all your cooking demands, including chicken, seafood, ribs, potatoes, vegetables and more.
- Designed to fit into limited space – width is only 18 1/8"– the **Junior Multi-Purpose Fryer** is equipped with casters for convenient mobility, and is narrow enough to roll through any standard door opening.



Capacity Information

Shortening Capacity: 25 lbs. (11.34 kg)

Standard Features

Automatic Oil Filtration System

Designed to complete a filter cycle within five minutes, the Automatic Oil Filtration System allows the operator to wash, rinse, drain and filter the oil in one motion. Refill is automatic and will increase your shortening life.



Giles Foodservice Equipment A Division of Giles Enterprises, Inc.

P.O. Box 210247 • 2750 Gunter Park Drive West • Montgomery, AL 36121-0247 USA
(334) 272-1457 • Fax (334) 272-3561 • Phone Toll Free 1-800-554-4537

Web Site: www.gilesent.com • Email: info@gilesent.com

Junior MULTI-PURPOSE FRYER

Model WOG-20MP

Job _____ Item No. _____ AIA# _____

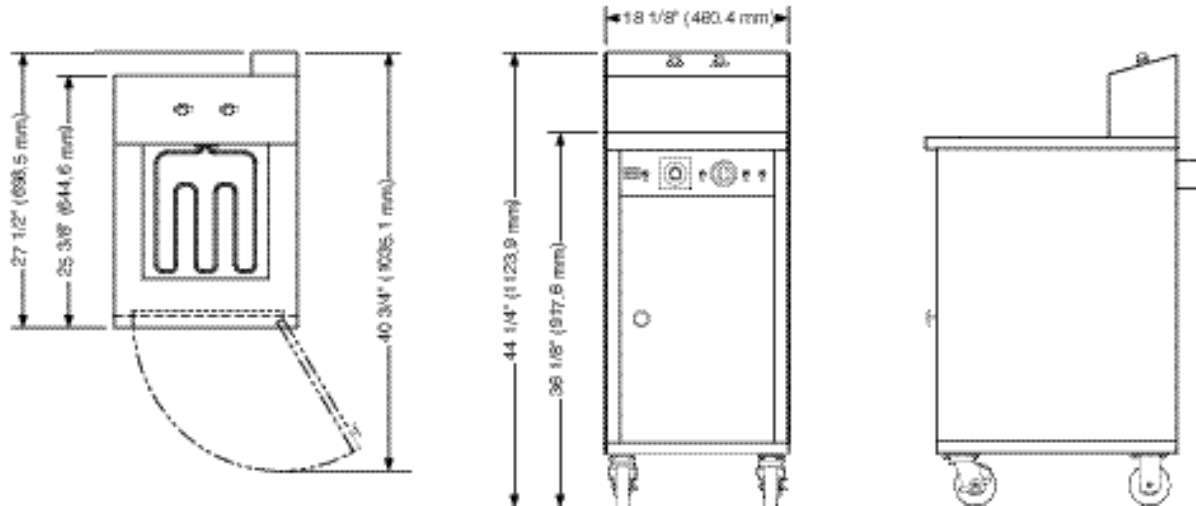

Inches [millimeters]

V31816A

Dimensions

Width: 18 1/8" 460 mm.
 Depth: 27 1/2" 698.5 mm.
 Height: 44 3/4" 1136.7 mm.
 Fry Vat: 12" x 13 1/2" x 5 1/2"
 304.8 mm. x 342.9 mm. x 139.7 mm.

Electrical Specifications

5335 Watts / 1 Phase
 208 V - 26 AMPS, 240 V - 22 AMPS
 (Service cord not provided)

Construction

Cabinet & Frypot: Polished Stainless Steel
 Heating Element: Patented Fire Bar
 Removable Basket (with handle)

Standard Accessories:

Unit is shipped with 2 Fry Baskets, Drain Hose Wand, 5 Sheets Filter Paper, Pot Brush, Kettle Drain Brush, Crumb Shovel, and Manual.

Weight

Shipping Weight: 283lbs (128.4 kg)

Shipping Size:

41" x 29" x 55" = 37.84 ft³
 1041.4 mm. x 736.6 mm. x 1397 mm. = 1.071 m³

Thermostats

Variable Solid State
 Range: 0-375° F 0-192° C.
 High Limit Thermostat:
 425° F. 218° C.

Listings

UL, NSF, CSA, CE, Canadian UL

Bidding Specifications

- Specify as model WOG-20MP.
- Specify voltage (208/240).
- Specify cycles (50 or 60).
- Specify UL listed (USA) or CSA listed (Canada) machine.
- Specify additional Fry Baskets (PN 78601) for backup batches.*
- Specify additional Filter Paper - (PN 72002) (case = 100 sheets) or Filter Powder - (PN 72004) (60 portion packs)*
- Specify optional Teflon Brush (PN 71100)
- Specify shipping method.
- For export consult factory.
*Additional charges

GILES
 FOODSERVICE EQUIPMENT®

We reserve the right to change specifications and product design without notice. Such revisions do not entitle the buyer to corresponding changes, improvements additions or replacements on previously purchased equipment.

P.O. Box 210247 • 2750 Gunter Park Drive West • Montgomery, AL 36121-0247 USA
 (334) 272-1457 • Fax (334) 272-3561 • Phone Toll Free 1-800-554-4537
 Web Site: www.gilesent.com • Email: info@gilesent.com

Printed in U.S.A. 12/00 Form 65857